



# **Installation, Operating and Maintenance Instructions:**

ETG-CK3-BW  
Butt-Weld 3-Piece Spring Check Valve

# Contents

---

**3**

Valve Information

---

**4**

Introduction

Transport and Storage Conditions

Installation Instructions

---

**5**

Operating Instructions

Maintenance Instructions

Reparation Instructions

---

**6**

Hygiene and Safety

# Valve Information

## ETG-CK3-BW

### Butt-Weld 3-Piece Spring Check Valve

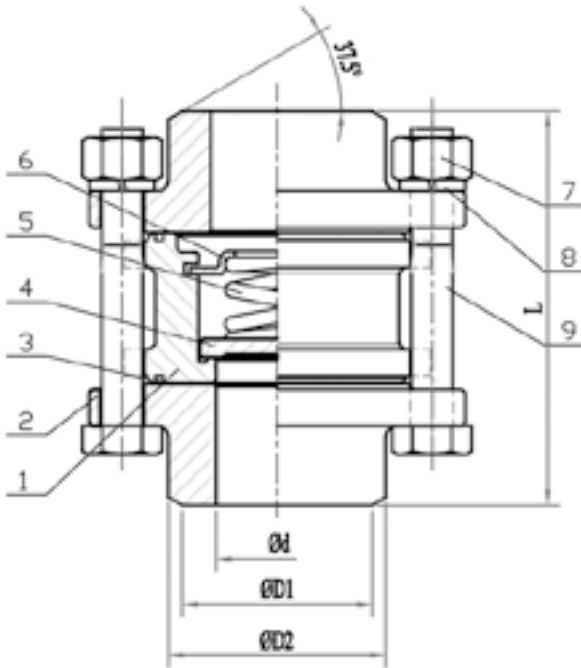

- ASTM A351 CF8M 316 Stainless Steel construction.
- 316 Stainless Steel Spring.
- 3-Pce Bolt together body construction.
- PTFE Body Seals, Metal Seat.
- 63 bar (1000 psi) pressure rated.
- -25 / +180 deg C Temp rated.
- Butt-Weld end connections to suit Nominal Bore Pipe (can be machined to suit Metric Pipe).
- CE marked (from 1.1/4").

#### Low "Cracking Pressures".

The 3-pce body construction allows the valve to be maintained.

We are able to offer full material certification to EN 10204 3.1.

Available stock size range: 1/2" - 2" (other sizes on Factory delivery).

Also available with BSP Screwed and Socket Weld Nominal Bore End Connections.

Item	Part	Material	Qty.
1	Body	CF8M	1
2	Cap	CF8M	2
3	Seal	PTFE	2
4	Disc	CF8M	1
5	Spring	SS316	1
6	Stopper	SS304	1
7	Nut	SS304	4(6)
8	Washer	SS304	4(6)
9	Bolt	SS304	4(6)

SIZE	d	D1	D2	L	Cracking Pressure mbar	Cv	Kv	Weight kg
1/2"	15	17	22	56	22-30	5.7	4.9	0.3
3/4"	20	22	27	65	22-30	10.3	8.8	0.43
1"	25	28	34	74	22-30	13.11	11.2	0.61
1-1/4"	32	35	43	83	24-32	24.2	20.7	1
1-1/2"	40	43	49	91	24-32	33.8	29	1.32
2"	50	54	61	110	24-32	46.7	40	2.14

Please note that no alternative spring ranges are available for this model of Check Valve.

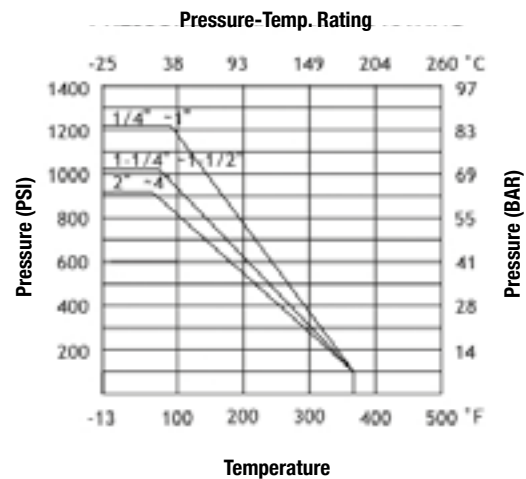

# Introduction

G.C. Supplies offers a wide range of valves, designed and assembled to handle and drive fluids in industrial procedures.

The compatibility of materials used to build the valves (see technical specifications) and the application of valves to the different industrial processes is at the user's risk. Valves will have an optimal behaviour when working conditions do not exceed the recommended pressure and temperature limits for which they have been designed.

## Transport and Storage Conditions

- Visual Inspection** It is important to conduct a visual inspection to check for any damage on the product that could have occurred during transport, unloading or placement. If you notice any kind of anomaly upon receiving the goods, please contact GC Supplies in order to resolve the issue.
- Storage** During storage it is recommended to keep valves in a dry and clean environment within the included protective wrapping to avoid damage or dirt accumulation. The protective wrap should not be removed until the valve is ready to be installed. Do not remove the protective end covering until the valve is ready for installation. This will reduce the possibility of materials damaging internal components in the valve. Valves that are to be stored outdoors should be positioned in a way such that water does not accumulate in the valve body.
- If valves are to be stored more than a year, they should be prepared in following steps.
- Do not remove the protective end covering.
  - Valve which will remain in storage for an excessive period of time should have a preservative applied to the external surface.
  - Do not store the valves outdoors or exposed in sun light.

## Installation Instructions

**Before installing and/or manipulating these elements, read these instructions carefully. If you fail to understand any of their content, please contact G.C. Supplies.**

- Preparation** Prior to shipment from the supplier, a preservative may have been applied to the inner body of the valve, this preservative should be removed with a solvent. The inside of the valve should be inspected and cleaned out using compressed air. Any adjacent piping must be clean and free from debris to prevent damage to the valve. To prevent valve deformation, inefficient operation or early maintenance problems, support piping should be added to each side of the valve. Make sure the valve is positioned such that there is sufficient space for any future maintenance. Install the valve according to the flow indicator on the valve body.
- Assembling** Valve pressure varies under different valve series, sizes, temperatures and the materials of the main parts. Please verify the application is within the limits and as described on the valve body or nameplate from G.C. Supplies. Valves should be operated for at least two complete

cycles before the installation to the pipe. Check the valve ends and the interconnecting pipe are compatible. The check valves are uni-directional and suitable to be installed for flow in any direction. Install the valve in such a way that extensive stresses in any direction on the valve are avoided. During the welding operation, be sure not to exceed 200°C. Ensure pipe alignment is accurate without any displacement.

# Operating Instructions

## Usage

Check Valves are usually used to prevent fluid from flowing back into the system. Check Valves are installed between flanges, which provide a leakproof lock when used adjusted to the pressure and temperature values for which they have been designed. Valve components must be fully compatible with the fluid circulating through the pipe, otherwise, the valve could be seriously damaged.

## Operation

By default, this kind of valve does not need to be operated. Opening and closing are automatic, depending on pressure and direction of the flow. For more information about the minimum opening pressure of the valve, please refer to the valve information stated previously in the document.

# Maintenance Instructions

Check valves are designed so that they do not need any lubrication and/or periodical maintenance during their life cycle. However, periodical checks will be useful to extend the service life of the valve and reduce installation problems:

- Keep the valve in a completely closed position.
- Verify all threads, locks, fasteners and threaded ends to check if they are loose or rusted. Tighten them if necessary.
- Inspect the valve and surrounding areas to verify if there is any leakage.

# Reparation Instructions

If fluid continues to circulate through the line once the valve is completely closed, the leakage may be caused by damage on the sealing surface or by an excessive erosion on the spring after many operational cycles. In both cases it will be necessary to disassemble the valve for repairing it.

However, for example it may be the case that, in an area difficult to access, it is more economically viable to directly replace the valve instead of repairing it.

**Disassembling**

You must remove the valve from the installation to repair it.

Make sure the line is cold, drained and depressurised.

Prepare a clean working area and adequate tools to perform mechanical tasks.

- Depressurise and empty the fluid before disassembly. Enacting caution with the fluid.
- Unscrew body bolts and nuts and remove valve.
- The spring and the disc can then be removed and replaced with new ones. Lubricate parts if necessary.
- Store the components in a clean area.

**Reassembling**

Before proceeding to reassemble the valve, make sure that reparation kit and/or pieces to be used are appropriate. When it is reassembled, maintaining cleanliness is essential for a long life cycle.

- a) Clean the area inside the Body and replace damaged or worn out pieces.
- b) Insert the Seat and the Disc O'Rings into their respective slots.
- c) Place the Disc in its working position and check if it got any damage during disassembling process. Then proceed with the Stem Stoppers and Screws.
- d) Reinstall the valve using the installation instructions.

# Hygiene and Safety

The following general safety notices supplement the specification warnings and cautions appearing elsewhere in this manual. They are recommended precautions that must be understood and applied during operation and maintenance of the equipment.

To avoid injury, never attempt to disassemble the valve while there's pressure present, either upstream or downstream.

Do not attempt to disassemble a valve while there is pressure in the pipeline. Ensure both upstream and downstream are removed. Disassemble with caution in the event all pressures have not been relieved.

To prevent valve deformation, inefficient operation, or early maintenance problems, support the piping on each side of valve.