



Installation, Operating and Maintenance Instructions:

ETG-GB1
Screwed Pattern Globe Valve

Contents

3

Valve Information

4

Introduction

Transport and Storage Conditions

Installation Instructions

5

Operating Instructions

Maintenance Instructions

Reparation Instructions

6

Hygiene and Safety

Valve Information

ETG-GB1

Screwed Pattern Globe Valve

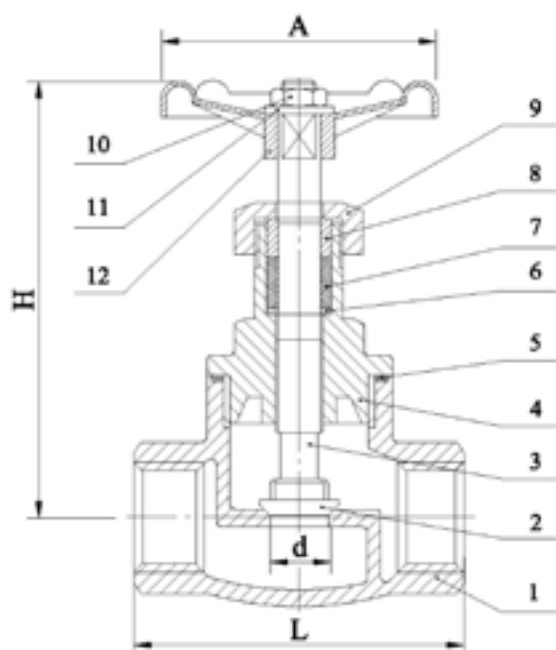

Item	Part	Material	Qty.
1	Body	CF8M	1
2	Seat	SS316	1
3	Stem	SS316	1
4	Cap	CF8M	1
5	Gasket	PTFE	1
6	Washer	SS304	1
7	Stem Packing	PTFE	1
8	Ring	SS304	1
9	Gland Ring	SS304	1
10	Handwheel Nut	SS304	1
11	Plate	SS304	1
12	Hand Wheel	CAST IRON	1

SIZE	d	L	H	A	Kgs
1/4"	10	67	79	65	0.5
3/8"	12	67	79	65	0.5
1/2"	15	67	79	65	0.48
3/4"	20	80	91	77	0.68
1"	25	89	106	77	0.96
1-1/4"	32	100	125	97	1.56
1-1/2"	40	118	136	97	2.20
2"	50	134	146	97	2.88

- ASTM A351 CF8M 316 Stainless Steel Body, Bonnet and Disc.
- 316 Stainless Steel Stem and Trim. Ductile Iron painted Handwheel.
- PTFE Gland Packing and Bonnet Seal.
- Screwed Bonnet. Non Rising Stem. Metal to Metal Taper Seat.
- 600 psi/g pressure rated.
- -20 / +180 deg C Temp rated.
- BSP screwed end connections to ISO 7/1 Rp (sizes 1/4"- 2") and NPT to ASME B1.20.1 (sizes 1/2" - 2").
- CE marked in accordance with the PED 2014/68/EU (from 1.1/4").

A good all round, robust general purpose Globe Valve used for both isolation and flow restriction duties. The 600 psi pressure rating is relatively unique as most companies are only able to offer a 200 psi unit. We are able to machine the valve ends to Socket Weld as an optional extra.

Available size range: 1/4" - 2"

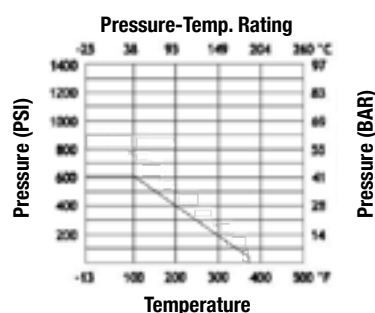

Introduction

G.C. Supplies offers a wide range of valves, designed and assembled to handle and drive fluids in industrial procedures.

The compatibility of materials used to build the valves (see technical specifications) and the application of valves to the different industrial processes is at the user's risk. Valves will have an optimal behaviour when working conditions do not exceed the recommended pressure and temperature limits for which they have been designed.

Transport and Storage Conditions

- Visual Inspection** It is important to conduct a visual inspection to check for any damage on the product that could have occurred during transport, unloading or placement. If you notice any kind of anomaly upon receiving the goods, please contact GC Supplies in order to resolve the issue.
- Storage** During storage it is recommended to keep valves in a dry and clean environment within the included protective wrapping to avoid damage or dirt accumulation. The protective wrap should not be removed until the valve is ready to be installed.

Before installing and/or manipulating these elements, read these instructions carefully. If you fail to understand any of their content, please contact G.C. Supplies.

Installation Instructions

- Preparation** Firstly, separate the valve from the valve wrapping. Serious problems may arise with the installation of a valve into an unclean pipe, make sure the pipe is not dirty before installing it.
- Check the valve is operating correctly by turning the handwheel both ways (close and open) and observing if the disc slides correctly. If this is not the case, check if there are any foreign particles inside the valve and repeat the whole operation until the desired outcome is achieved. If the disc does not move smoothly, the valve must not be installed.
- Assembling** Make sure the valve's pipe and threaded ends are clean and are compatible with one another. Apply an appropriate jointing material onto the pipes' threaded ends and thread the valve on, being careful not to excessively tighten the threaded ends. Do not use valve's handwheel as a lever to thread the valve onto the pipe.
- When tightening the valve, it is recommended to use a spanner or monkey wrench on the hexagonal area of the valves edges or in the body central assembly; the force applied being less than 30 Nm.
- Design for this kind of regulation valve allows only one position for assembling it to the pipe, this is illustrated by an arrow in the valve's body that indicates the direction in which the fluid needs to circulate.**
- If possible, it is recommended to install the valve in horizontal position and the handwheel upwards. It is also recommended to use filters in the pipe to extend its lifecycle.

Operating Instructions

- Usage** This valve provides a leakproof lock when used adjusted to the pressure and temperature values for which they have been designed for. Valve components must be fully compatible with the fluid circulating through the pipe, otherwise, the valve could be seriously damaged.
- Operation** When operating the valve you must avoid excessive force with the handwheel. To close, turn the handwheel clockwise and to open, turn the handwheel anticlockwise.

Maintenance Instructions

Frequency, place and process of maintenance should be determined by taking into account by usage of the product. However, periodical checks explained below will be useful to extend the service life of the valve and reduce installation problems.

- Valves must not remain in open or closed position for a long period of time. It is recommended, if the process allows for it, to operate it for control purposes every six months.
- Verify possible leaks in the stem area; in case they exist, proceed to tighten the gland nut. If leak persists, valve should be replaced.
- Verify possible leaks through the line (due to closure); this defect is probably caused by deposition of impurities between the disc and the seat, transported by the fluid. Disassemble the valve from the pipe, clean it thoroughly and reinstall it. If the problem persists you should change the valve, since it is possible that some metallic parts used for closure are damaged (erosion / corrosion).

Reparation Instructions

Repairing this type of valve is simply not cost-effective, due to their easy assembly and reduced production cost. We recommend complete replacement.

Before disassembling the pipework surrounding the valve to clean or replace it, make sure that line has been isolated and depressurised to prevent a serious accident to staff or damage to the system. Before installing a new valve, check if it meets the same requirements of the valve being replaced.

Hygiene and Safety

The fluids that go through the valve can be corrosive, toxic, flammable or pollutant. When operating valves, you must follow the operation instructions.

It is recommended that you:

- Protect your eyes.
- Wear gloves and appropriate working clothes.
- Wear safety footwear.
- Wear a helmet.
- Have running water to hand.
- Have an extinguisher to hand when work with flammable fluids.

Before removing a valve from a pipe, check always if the line is completely cold, drained and depressurised.

Operate the valve in open position to make sure there is no pressure in the internal cavity.